

Security Service – Managed IDS/IPS Service

Fortify security against from outside attackers by identifying abnormal activities through patterns, analyzing the correlations between HIDS (Host-based Intrusion Detection System) events and WAF logs.

Managed IDS/IPS Service Structure

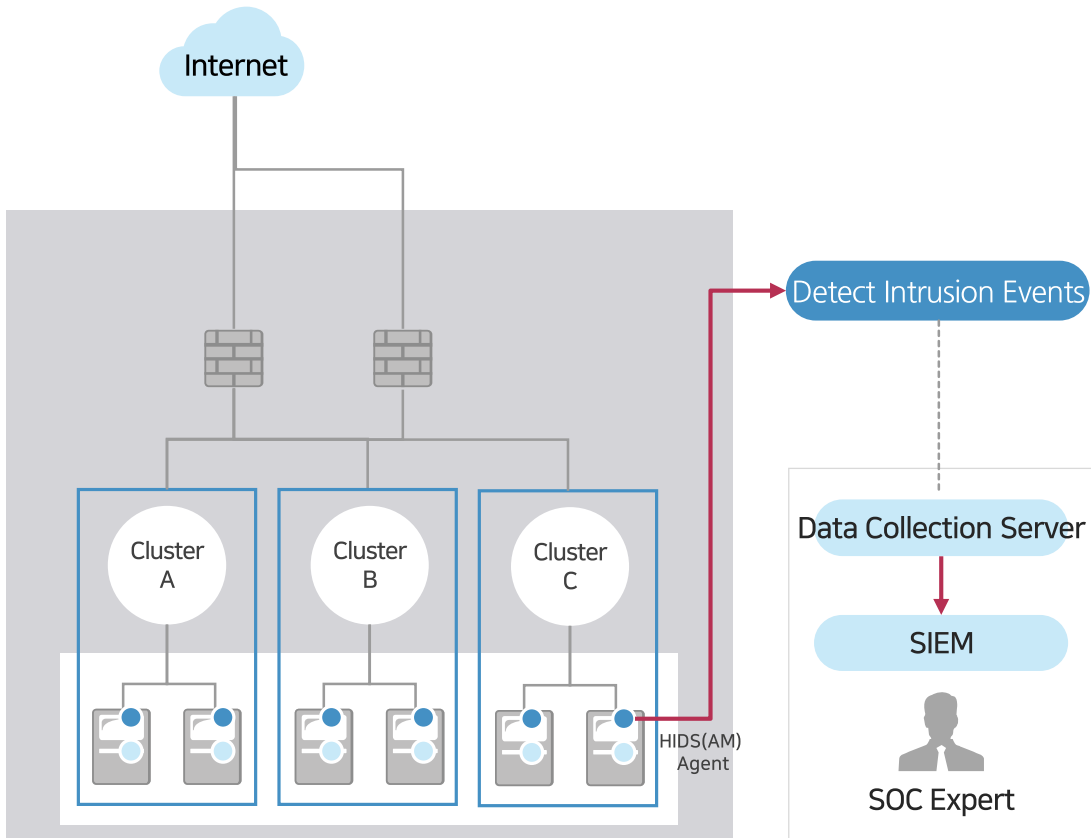

Log Collection & Event Detection/Alert System

Log Collection	<ul style="list-style-type: none"> Send encrypted event logs through HIDS Agent (same as Anti-malware Agent) to data collection server (detection logs) 						
Event Detection	<ul style="list-style-type: none"> Detect GET / POST attacks on website Detect abnormal behaviors based on pattern analysis Correlation analysis with WAF logs 						
Alert/Notification Criteria	<table border="1"> <thead> <tr> <th data-bbox="1513 1013 1824 1071">Normal</th> <th data-bbox="1824 1013 2135 1071">Need Attention</th> <th data-bbox="2135 1013 2438 1071">Emergency</th> </tr> </thead> <tbody> <tr> <td data-bbox="1513 1071 1824 1316"> <ul style="list-style-type: none"> Suspicious activities Email notification </td> <td data-bbox="1824 1071 2135 1316"> <ul style="list-style-type: none"> Failed web hacking attempts SQL Injection, XSS, etc. Detailed event analysis Confirmation requests (email) </td> <td data-bbox="2135 1071 2438 1316"> <ul style="list-style-type: none"> Successful web hacking attempts Detailed event analysis Reporting (Phone/SMS/email) </td> </tr> </tbody> </table>	Normal	Need Attention	Emergency	<ul style="list-style-type: none"> Suspicious activities Email notification 	<ul style="list-style-type: none"> Failed web hacking attempts SQL Injection, XSS, etc. Detailed event analysis Confirmation requests (email) 	<ul style="list-style-type: none"> Successful web hacking attempts Detailed event analysis Reporting (Phone/SMS/email)
Normal	Need Attention	Emergency					
<ul style="list-style-type: none"> Suspicious activities Email notification 	<ul style="list-style-type: none"> Failed web hacking attempts SQL Injection, XSS, etc. Detailed event analysis Confirmation requests (email) 	<ul style="list-style-type: none"> Successful web hacking attempts Detailed event analysis Reporting (Phone/SMS/email) 					